



DEFENSE

GLOBAL SOLUTIONS



ALLWEILER® IMO®
TUSHACO® WARREN®



EXCELLENCE IN FLOW CONTROL

A NAVY'S MISSIONS MAY CHANGE. But service through war and peace requires one constant – your ships and equipment must perform at all times, regardless of the conditions. Mission-critical is your way of life.

CIRCOR understands the challenges you face. And whether your application requires an engineered pump, a customized solution or turnkey module, we are on board to meet your needs. From the flight deck to the engine room, from the superstructure to gun turrets, our products and expertise are found globally, operating reliably 24/7.

Navies and military installations worldwide have placed their confidence and trust in CIRCOR for over 70 years because we have delivered without fail through:

- › People who bring the engineering expertise, problem-solving orientation and commitment to deliver innovative fluid handling and fluid transfer solutions that tackle your toughest challenges, the first time, every time.
- › Products and systems that deliver a wide range of solutions to meet your demanding and exacting specifications, whether you need a custom engineered system or a plug-and-play package module.
- › Dedication to global service and support that means we are there wherever and whenever you need us, with service centers located in the United States, India and France.

Bottom line: Mission-critical is our way of life, too. CIRCOR is the single source for your navy-specific solutions as we redefine what's possible in defense solutions fluid handling.

PRODUCTS THAT FOCUS ON PERFORMANCE & RELIABILITY

Because of the quality we build into our pump packages and systems, valves and actuators, OEMs and the navies of the world feel confident, assured in the reliability of their CIRCOR products. We develop solutions that reduce maintenance costs, energy costs and avoid unscheduled downtime and repairs. And we focus on performance and unsurpassed reliability.

We engineer and build products for your critical applications, including:

- › Fire main pump skids
- › Aircraft fuelling systems
- › Lubrication equipment and skids
- › Hydraulics
- › Engine room
- › Water transfer

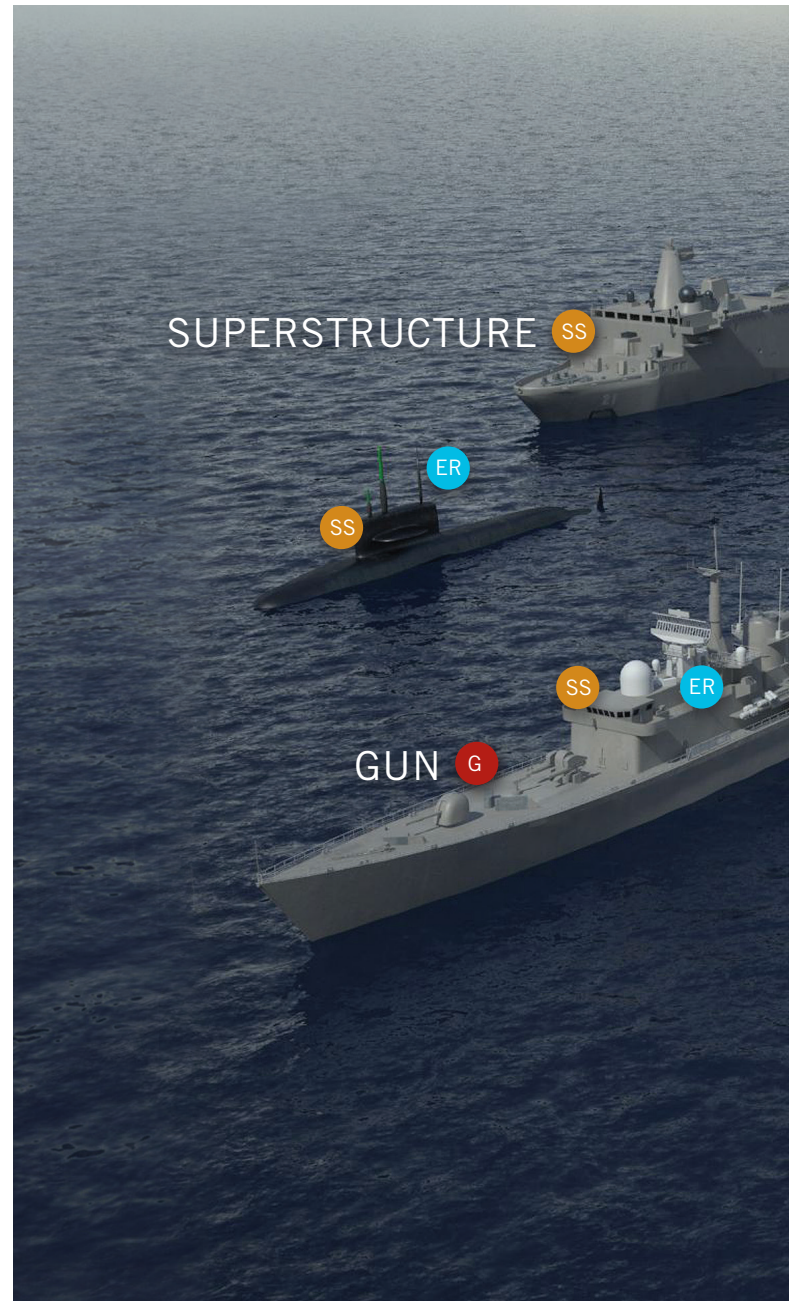

SUPERSTRUCTURE

SS

- › Hydraulics
- › Air conditioning
- › Water transfer

FLIGHT DECK

FD

- › Aircraft fuel transfer
- › Firefighting
- › Wash down
- › Deluge
- › Hydraulics

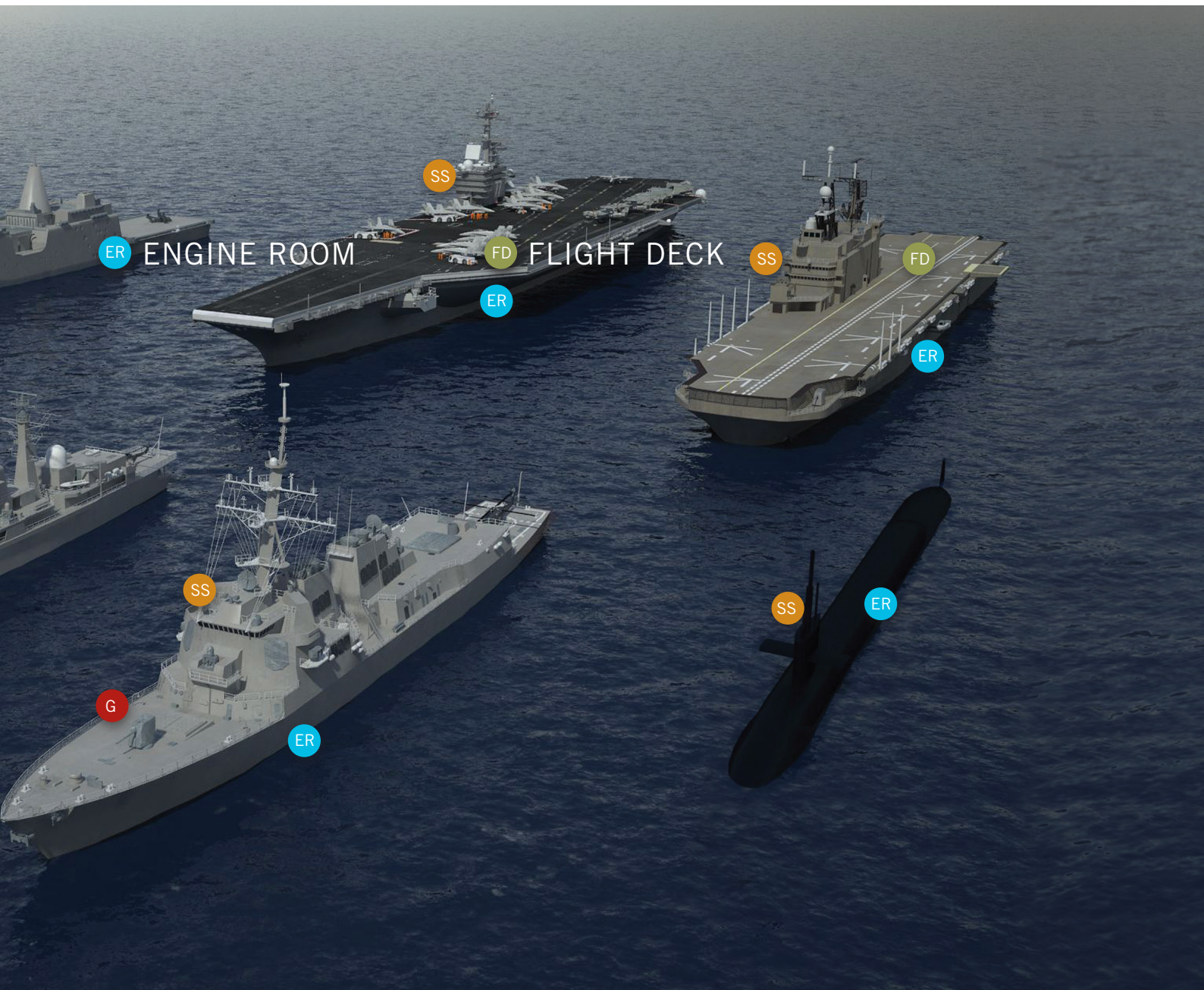

ENGINE ROOM

- › Ballast
- › Cooling water (sea & fresh)
- › Hot-water circulation
- › Fuel & lubricating oil
- › Hydrophore
- › Boiler feed
- › Sewage & sanitary services
- › General service
- › Condensate
- › Firefighting
- › Bilge
- › Main LO circulation
- › Sludge
- › Gearbox services
- › Electric propulsion
- › Motor cooling
- › Trim/weight compensation

ER

GUN

- › Firefighting pumps
- › Weapons cooling
- › Hydraulics

G

PUMPS

Your application needs in Defense are diverse, so CIRCOR delivers a variety of pump technologies from the names you know and trust: Allweiler, Imo, Tushaco, Warren. With both standard and highly-engineered designs, we're able to deliver pumps that meet your specific application needs.

- › Flow rates from 1 to 7000m³/hr.(3 to 30,000+ USGPM)
- › Pressures up to 200 bar g (3,000 psig)
- › Performance up to 375 kw (500 HP)
- › Materials from cast iron to titanium, including steel, duplex stainless, bronze, Monel®
- › Military standards: Products and solutions delivered to meet the various standards including U.S. MIL Spec, DEFSTAN, NES together with the Class Societies Naval rules such as ABS, LRS, DNV and GL
- › Special requirements: Customer specific test criteris based on Military standards or customer standards: Capacity - Pressure - Hydrostatic - Suction Lift - Shock Environmental Vibration - Airborne Noise - Structureborne Noise - Liquidborne Noise

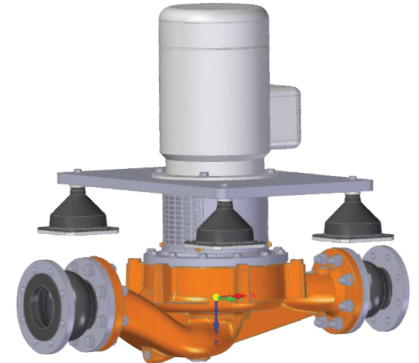

CENTRIFUGAL PUMPS

TECHNOLOGIES

Coupled - Close Coupled - Propeller
Mixed Flow - Multistage - Special Low Noise

SERVICES

Sea Water - Condensate - Heeling - Fresh Water
Distilling Plant - Ballast - Fire - Feed Water

POSITIVE DISPLACEMENT PUMPS

TECHNOLOGIES

Untimed Screw - Timed Screw - Special Low Noise
Gear - Progressive Cavity - Reciprocating

SERVICES

Lube Oil - Transfer - Fuel Oil - Stripping
Hydraulics - Purifier / Coalescer Feed





VALVES & ACTUATORS

For over 30 years, the U.S. Navy has relied upon products from CIRCOR's Portland Valve, to meet your fluid control needs from isolation valves to advanced smart control valves.

- › Highly engineered valves for critical applications on submarine/surface ship damage control systems
- › Specialized control valves
- › Programmable motor-operated valves for localized PID or autonomous control
- › MIL Spec butterfly valves and electric actuators
- › Motor-operated valves

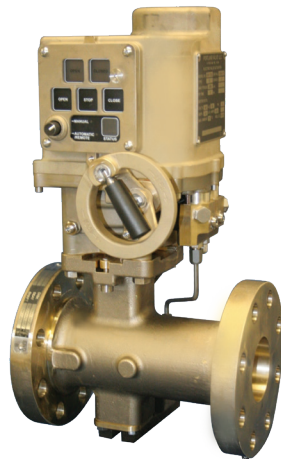

SYSTEMS

Whether you need a turnkey, plug-and-play pump package or a complete custom engineered system, CIRCOR stands ready to address your toughest application challenges.

- › Helo Refuelling Modules
- › Fresh and Sea Water Pressure Sets (Hydrophore)
- › Diesel Driven Fire Sets
- › Lubrication Modules

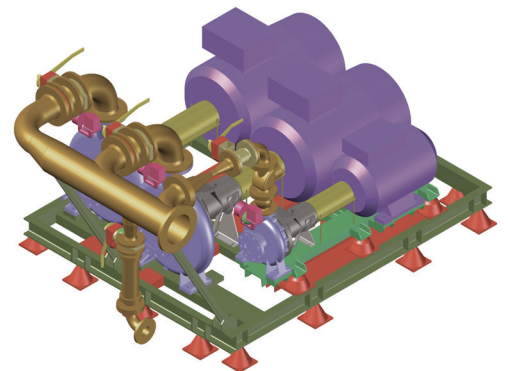



AFTERMARKET SERVICES – U.S.

CIRCOR Service and Repair Centers in San Diego, California and Norfolk, Virginia, provide the following equipment support services 24/7/365:

- › Factory-trained and supported technicians
- › Stocked parts inventory
- › Turnkey repairs
- › Rotatable pool programs
- › Factory-engineered upgrades
- › Specialized services, such as equipment flushing and training

AFTERMARKET SERVICES – GLOBAL

- › Factory service and repair
- › Factory trained service engineers
- › Spare parts inventory

SUPPORT BEYOND THE CALL OF DUTY

Whether your ship is in port or dry dock, or at sea, CIRCOR is there with you. Global service means just that. We work to minimize downtime, so your ships are always ready when duty calls. But when an emergency occurs, we stand ready too with the support you need. You can count on us to:

- › Make sure you have access to the latest technical data and product documentation.
- › Deliver standard spare parts within 48 hours.
- › Support you from service centers, located in the United States, France and India.
- › Schedule specialized services, such as lubrication equipment flushing and training, at your convenience.

CIRCOR technicians are available “around the clock and around the world,” wherever and whenever you need them.



GLOBAL SUPPORT IN STRATEGIC LOCATIONS

The militaries of the world may differ in mission, but they do share a common challenge: to perform under the harshest conditions, at any time, in any location around the world. That's why CIRCOR has established three centers of excellence in strategic global locations – the Americas, Europe and India – each focused on supporting your critical mission with ours: flawless fluid-handling services whenever and wherever you need them.





MISSION CRITICAL. IT'S YOUR WAY OF LIFE. AND IT'S OURS, TOO.

CIRCOR shares your commitment to the mission-critical way of life. That's why we're redefining what's possible in global defense, collaborating with you from project inception to installation to on-board service, to provide the:

- › In-depth knowledge of naval specifications and of your world to help you deal with the toughest application challenges.
- › Quality, innovation and reliability you need from products and systems to help you ensure better performance.
- › Global service and support, when and where you need it, to help you deliver on your mission without fail.

Mission Critical. It's the foundation of our commitment to you, every hour of every day.



CIRCOR is a market-leading, global provider of integrated flow control solutions, specializing in the manufacture of highly engineered valves, instrumentation, pumps, pipeline products and services, and associated products, for critical and sever service applications in the oil and gas, power generation, industrial, process, maritime, aerospace, and defense industries.

Excellence in Flow Control

Asia | Europe | Middle East | North America | South America

SES International B.V.
Sluisstraat 12 Delden,
NL-7491GA Netherlands
+31 74 377 7300

CIRCOR
1710 Airport Rd
Monroe, NC 28110
USA

Warren Pumps LLC
82 Bridges Avenue
P.O. Box 969
Warren, MA 01083-0969
USA
+1(413) 436-7711

Allweiler India Pvt. Ltd.
CIRCOR
Plot No. 1, 22, 23, 653/1,
Somnath Co-op.
Indl. Soc. Ltd.,
Somnath-Kachigam Road,
Daman, 396 210. India



ALLWEILER® IMO®
TUSHACO® WARREN®

circorpt.com/circor-defense-solutions