

2BIC SERIES PUMP

THREE-SCREW CLOSE COUPLED PUMPS STANDARD PRODUCT SPECIFICATIONS

COLFAX FLUID HANDLING INDUSTRIAL SOLUTIONS

The 2BIC series pump is suitable for operation on clean lubricating liquid and is especially well-suited for low pressure lubrication services. Typical applications are found on rotating machinery and other equipment where forced oil flow is required.

The 2BIC series is available in six displacements across three frame sizes. The pump case and covers are aluminum.

The 2BIC series three-screw pump delivers the benefits that matter most to OEM's: quiet operation, long service life, low pressure ripple and maximum energy savings, resulting in the highest "Total Savings of Ownership" across the entire life cycle of your pumping equipment.

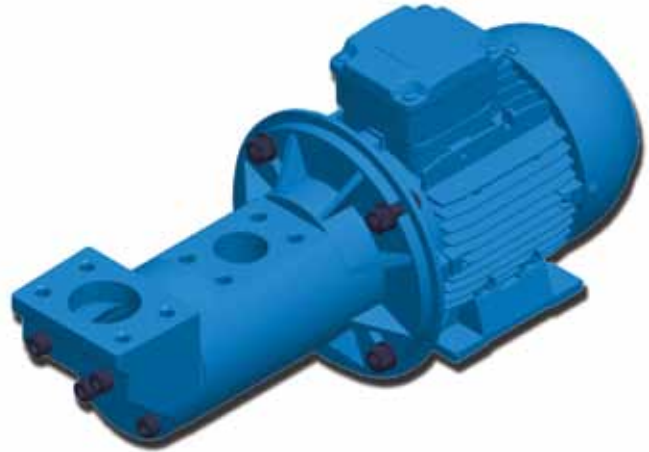

2BIC - 143 WITH ELECTRIC MOTOR
Typical sizes 095 through 187

PRODUCT SPECIFICATIONS

Casing / rotor housing	Aluminum alloy
Power rotor	Ductile iron
Idler rotor	Ductile iron
O-rings	Fluorocarbon
Seal & bearing	Liptype fluorocarbon shaft seal. Open, product lubricated ball bearing
Outlet pressure	To 12 BAR (175 psi-g) - not to exceed 11 BAR differential (160 psi-d)
Inlet pressure	1.72 BAR (25 psi-g)
Viscosity	2 cSt (33 ssu) minimum - 216 cSt (1000 ssu) maximum
Temperature	-18 - 82° C (0 - 180° F)
Speed	To 3600 RPM
Drive	Direct only
Rotation	Clockwise facing pump driveshaft
Mounting	Face flange only. Pump is designed with a female shaft and is suitable for flange mounting with IEC flanged motors.
Port connections	ISO 6162-1 Type 1 (SAE Code 61) drilled and tapped for metric bolting; Inlet head is rotatable in 90° increments
Filtration	60 mesh recommended
Accessories	Available with or without electric motor and SAE port fittings

2BIC SERIES PUMP

Pumps in the 2BIC series are fitted with a spring-backed lip seal. The elastomeric components are made of fluorocarbon material. The ball bearing is located within the pumped liquid and receives constant lubrication and cooling via the pumped fluid. Inlet and outlet ports are per ISO6162-1 Type 1 (SAE Code 61) and are rotatable in 90° increments. The pump mounting flange is designed to couple directly with an IEC "FF" motor face flange.

AA2BIC CLOSE COUPLED PRODUCT WITH IEC FRAME MOTOR NOMENCLATURE

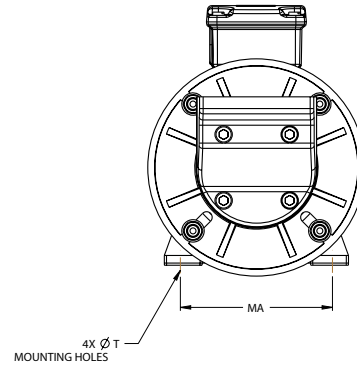
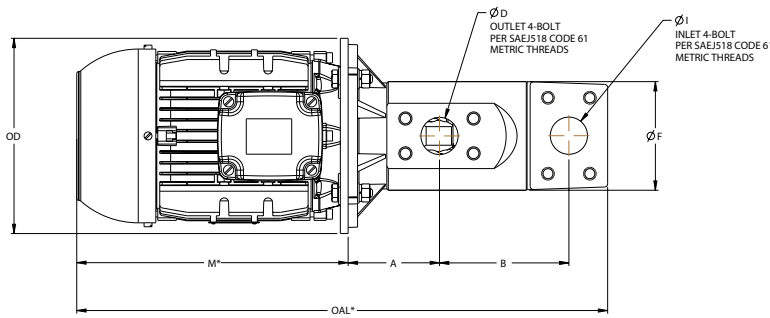
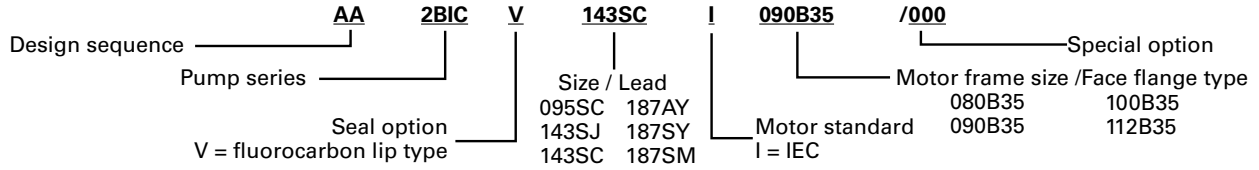

* TYPICAL - SUBJECT TO CHANGE BASED ON MOTOR VENDOR

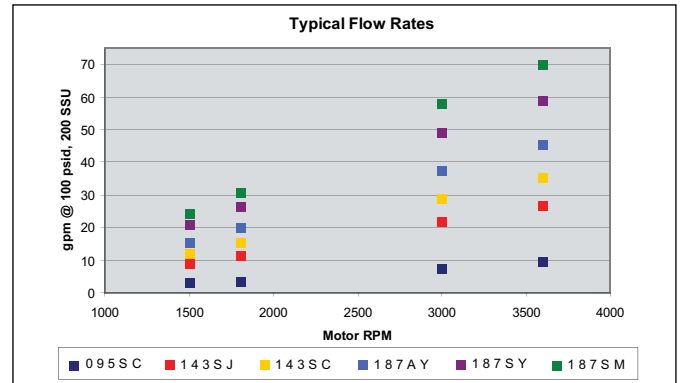
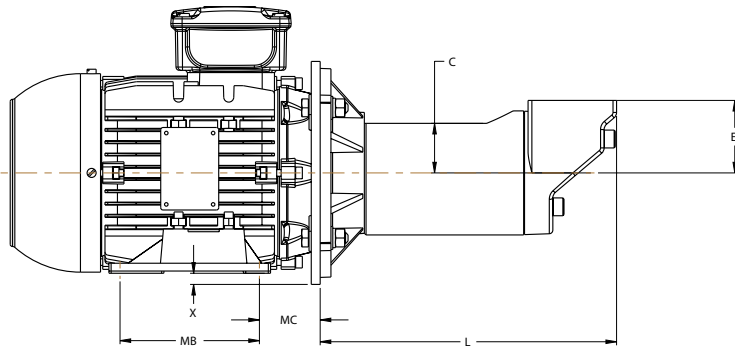

P/N	ASSY: AA2BIC/V...	A	B	C	D	E	F	I	L	M	OAL	MA	MB	MC	OD	T	X
3615/001	095SCI080	94	93	33.3	19	57	70	25	216	236	452	125	100	50	200	10.2	20
3635/001	143SCI090									278	547	140	100	50	200	10.2	10
3635/002	143SJI090	97	132	44.5	38	65	111	38	269	236	505	125	100	56	200	10.2	20
3635/003	143SCI080																
3635/004	143SJI080																
3650/001	187AY080									236	556	125	100	50	200	10.2	20
3650/002	187SY080																
3650/003	187SM080																
3650/004	187AY090																
3650/005	187SY090	114	166	57.2	38	65	111	51	320	278	598	140	100	56	200	10.2	10
3650/006	187SM090																
3650/007	187AY100																
3650/008	187SY100																
3650/009	187SM100									316	636	160	112	63	250	12	25

Colfax Fluid Handling

1710 Airport Road
 Monroe, NC 28110-5020
 Tel: +1.704.289.6511
 Tol: +1.877.853.7867

www.colfaxcorp.com/industrial

Industrial Solutions Products & Services

ALLWEILER® HOUTTUIN™ IMO® WARREN®

COLFAX, ALLWEILER, HOUTTUIN, IMO and WARREN are registered trademarks of the Colfax Corporation or its subsidiaries in the U.S. and/or other countries. © 2013 Colfax Corporation. All rights reserved. GB-CFH001-2BIC-2/13

COLFAX
 Fluid Handling

REDEFINING WHAT'S POSSIBLE